

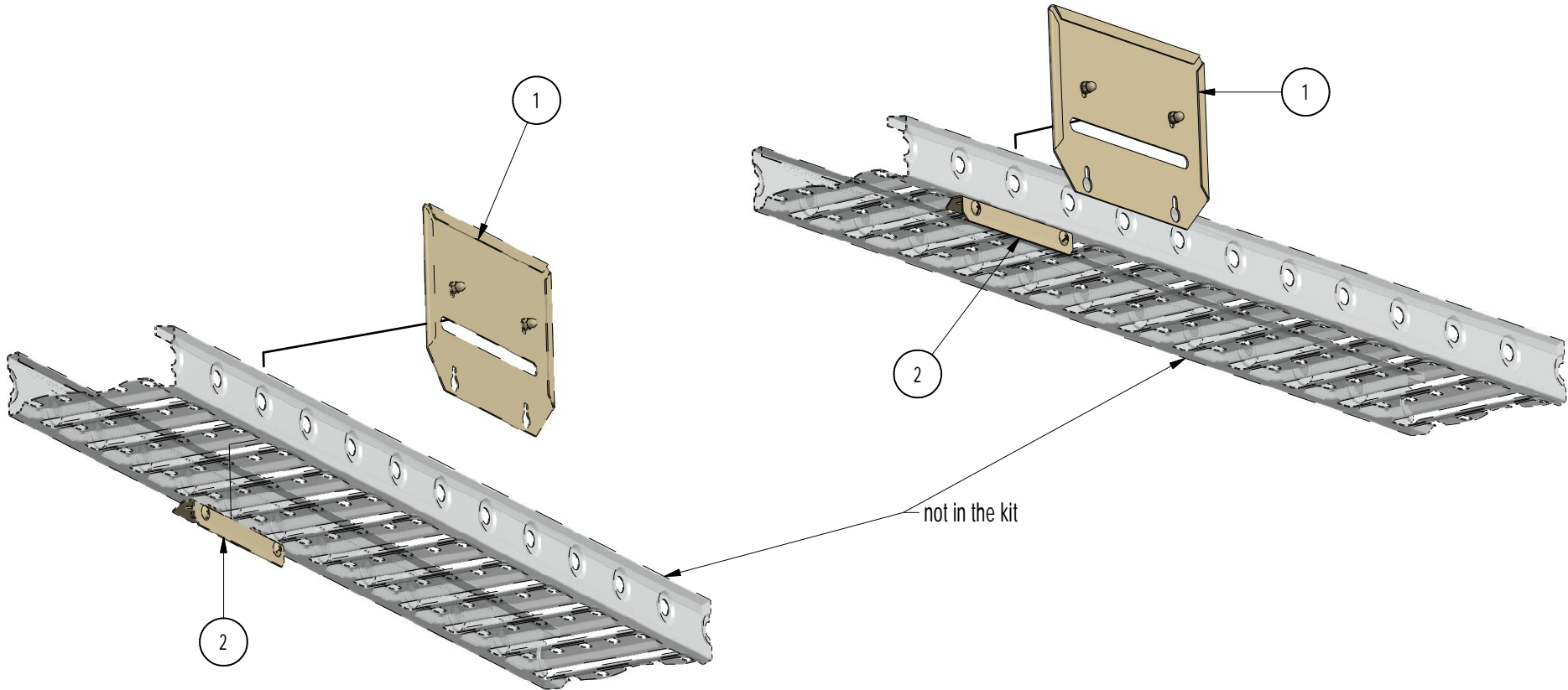

Parts List				
ITEM	QTY	PART NUMBER	DESCRIPTION	MATERIAL
1	1	B9815-06	PREASSEMBLY OF CABLE TRAY SIDE EXTENSION PANEL	
2	1	B9815-07	PREASSEMBLY ORF CLIP-ON' CABLE-TRAY SIDE EXTENSION MOUNING BRACKET	



**BRESEIGHT AUSTRALIA** PTY.LTD.  
A.C.N. 064 251 538 **PRECISION ENGINEERS**

**EXCHANGE SUPERSTRUCTURE**  
**CABLE TRAY 'ADD-ON' SIDE EXTENSION CABLE MANAGEMENT KIT**  
**ASSEMBLY VIEW & PACKING LIST**

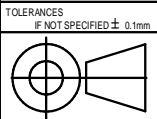

**TOLERANCES**  
IF NOT SPECIFIED ± 0.1mm

**COPYRIGHT**  
NO PART OF THIS WORK MAY BE PRODUCED OR COPIED IN ANY FORM BY ANY MEANS WITHOUT THE PRIOR WRITTEN PERMISSION OF 'BRESEIGHT'. THE WORK MAY ONLY BE USED FOR SUCH PURPOSES AS ARE AUTHORISED BY 'BRESEIGHT' AT.  
FAX : (02) 9933 3699, EMAIL breselght@breselght.com.au



REV.	DATE:	DESCRIPTION	APPD.
0	11.05.2012	RELEASED FOR PRODUCTION	M.P.
PRLM1	11.04.2012	RELEASED FOR SAMPLE PRODUCTION	M.P.

print date: **NETT WEIGHT: N/A** Released - 3/05/2012 - M.P.

DWG. No.	REV. No.	SHEET	DWG. SCALE
<b>B9815</b>	0	1 / 1	NA
			DRAWN W.R. (A4-INV)

